

INDUSTRIAL & OTR TIRES



 **starmaxx**
IND - OTR TIRES

The power means for us
take the responsibility of work.

Stx ND 31



starmaxx
IND - OTR TIRES

www.starmaxx.com

CONTENTS

3 Range of Starmaxx Ind-Otr Tires

4 Starmaxx Ind-Otr Tires by Size

8 General Information

Forklift

SMF 20 SMF 30 SMF 40
12 13 14

Compactor

SM S2 SM C1
15 16

Skid Steer

SM 135
17

Radial Industrial Traction

Stx ND31
18

Industrial / Industrial Traction

TR 45 SM ND SM 125 TR 60 SM 5 SM PL
19 20 23 22 23 24

Excavator

SM 38
25

Grader Radial / Grader

Stx L42 SG 200 SG 300
28 29 30

Earthmover-Loader Radial / Earthmover

Stx L31 (E3-L3) SM 57 (E3) SM 60 (E3)
31 32 33

Loader Radial / Loader

Stx L31 (L3) SM 57 (L3) SM 60 (L3) SM 70 (L3) SM 70 (L4)
34 35 36 37 38

Port Application

C+STACKER C+STACKER SMOOTH
39 40

It's hard to be in your shoes.

That is why we produce the best off road tires for you.



starmaxx
IND - OTR TIRES

www.starmaxx.com

Strong, durable, affordable off road tires.

Forklift



Forklift SMF 20



Forklift SMF 30



Forklift SMF 40

Compactor



Compactor SM S2

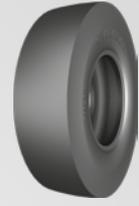

Compactor SM C1

Skid Steer



Skid Steer SM 135

Radial Industrial Traction



Radial Industrial Traction Stx ND31

Industrial / Industrial Traction



Industrial TR 45



Industrial Traction SM ND



Industrial Traction SM 125



Industrial Traction TR 60



Industrial Traction SM 5



Industrial Traction SM PL



Excavator SM 38

Excavator

Grader Radial / Grader



Grader Radial Stx L42



Grader SG 200



Grader SG 300

Earthmover-Loader Radial / Earthmover



Earthmover-Loader Radial Stx L31 (E3-L3)



Earthmover SM 57 (E3)



Earthmover SM 60 (E3)

Loader Radial / Loader



Loader Radial Stx L31 (L3)



Loader SM 57 (L3)



Loader SM 60 (L3)



Loader SM 70 (L3)



Loader SM 70 (L4)

Port Application



Port Application C+STACKER

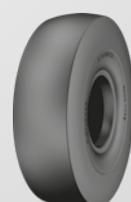

Port Application C+STACKER SMOOTH



FORKLIFT SMF 20

- 23x5-13
- 4.00-8
- 5.00-8
- 18x7-8
- 6.00-9
- 21x8-9
- 6.50-10
- 23x9-10
- 7.00-12
- 27x10-12
- 8.15-15
- 8.25-15



COMPACTOR SM S2

- 23.1-26



FORKLIFT SMF 30

- 4.00-8
- 5.00-8
- 18x7-8
- 16x6-8
- 6.00-9
- 21x8-9
- 6.50-10
- 23x9-10
- 7.00-12
- 23x5-(13)
- 7.50-15
- 8.15-15
- 250-15
- 300-15
- 23x10-12*
- 27x10-12*



COMPACTOR SM C1

- 11.00-20
- 13.0/80 R20



FORKLIFT SM F40

- 6.00-9
- 6.50-10
- 7.00-12
- 8.15-15
- 8.25-15



SKID STEER SM 135

- 10-16.5
- 12-16.5

*UNDERDEVELOPMENT



**RADIAL INDUSTRIAL
TRACTION Stx ND31**

- 340/80R18
(12.5/80 R18)
- 440/80R28
(16.9 R28)
- 405/70 R20
(16.0/70 R20)
- 460/70 R24
(17.5L R24)
- 400/70 R20
(16.0/70 R20)



INDUSTRIAL TRACTION SM 125

- 12.5/80-18
- 340/80-18
- 16.0/70-20
- 16.9-24
- 16.0/70-24
- 405/70-24
- 19.5L-24
- 440/80-24
- 16.5/85-24
- 16.9-28
- 440/80-28
- 18.4-26
- 480/80-26



INDUSTRIAL TR 45

- 11L-16 SL



INDUSTRIAL TRACTION TR 60

- 15.5/80-24



INDUSTRIAL TRACTION SM ND

- 10-16.5
- 10.0/75-15.3
- 11.5/80-15.3
- 12-16.5
- 10.5/80-18
- 280/80-18
- 16.0/70-20
- 405/70-20
- 16.5/85-28
- 480/80-26
- 23.1-26
- 16.0/70-24
- 14.5-20
- 405/70-24



INDUSTRIAL TRACTION SM 5

- 16.9-30
- 18.4-26

INDUSTRIAL TRACTION SM PL
15.5-25



GRADER SG 300
16.00-24



EXCAVATOR SM 38
7.50-20
9.00-20
10.00-20



**EARTHMOVER-LOADER
RADIAL
Stx L31 (E3-L3)**
26.5 R25



**GRADER RADIAL
Stx L42**
14.00 R24



**EARTHMOVER SM 57
(E3)**
14.00-24



GRADER SG 200
13.00-24
14.00-24



EARTHMOVER SM 60 (E3)
16.00-25
18.00-25

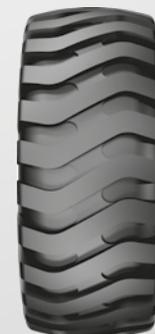



**LOADER RADIAL
Stx L31 (L3)**

26.5 R25



LOADER SM 70 (L4)

26.5-25
29.5-25



LOADER SM 57 (L3)

17.5-25
20.5-25
23.5-25



**PORT APPLICATION
C+STACKER
18.00-25**



LOADER SM 60 (L3)

17.5-25
20.5-25
23.5-25
26.5-25
29.5-25



**PORT APPLICATION
C+STACKER SMOOTH
18.00-25**



LOADER SM 70 (L3)

15.5-25
17.5-25
20.5-25
23.5-25
26.5-25
29.5-25

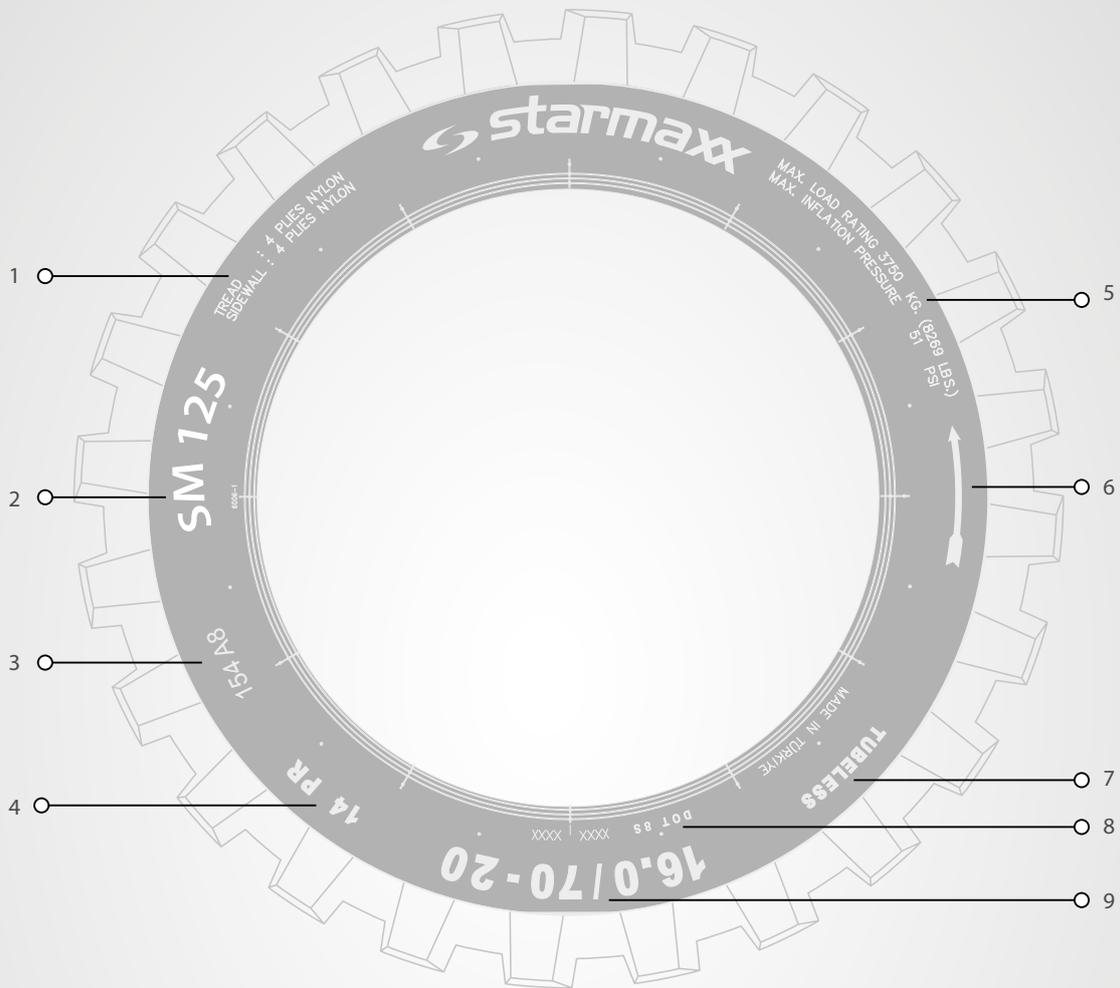

1- Construction Information
Tread: 4 Plies of Nylon
Sidewall: 4 Plies of Nylon

4- Ply Rating
5- Maximum Load (Inflation Pressure)

8- DOT Symbol – Week Code
9- Size

2- Pattern Name

6- Rotation Direction

3- Speed and Load Index

7- Tubeless

UNIT CONVERSION TABLE

Unit	Abbreviation	Conversion Coefficient	Abbreviation	Unit	Abbreviation	Conversion Coefficient
Length						
inch	in	x 0,0254	= m	(Metre)	x 39,37	= in
foot	ft	x 0,3048	= m	(Metre)	x 3,281	= ft
yard	yd	x 0,9144	= m	(Metre)	x 1,0936	= yd
mile	ml	x 1,6093	= km	(Kilometre)	x 0,6214	= mile
Load						
Pound	lb	x 0,4536	= kg	(Kilogramme)	x 2,205	= lb
Long Ton (U.K) 2240 lbs	lg ton	x 1,016	=T	(Metric Tonne)	x 0,984	= lg ton
Short Ton (U.S) 2000 lbs	sh ton	x 0,907	=T	(Metric Tonne)	x 1,103	= sh ton
Pressure						
Kilo - Pascal	kPa	x 0,01	= bar	(Bar)	x 100	= kPa
Atmosphere (at sea level)	atm	x 0,986	= bar	(Bar)	x 1,014	= atm
Pound/Square inch	ibf/in ² (psi)	x 0,0703	= kg/cnf	(Kilogramme/cm ²)	x 14,22	ibf/in ² (psi)
Pound/Square inch	ibf/in ² (psi)	x 0,069	= bar	(Bar)	x 14,513	ibf/in ² (psi)
Pound/Square inch	ibf/in ² (psi)	x 0,068	= atm	(Atmosphere)	x 14,7	ibf/in ² (psi)
Pound/Square inch	ibf/in ² (psi)	x 6,895	= kPa	(Kilo Pascal)	x 0,145	ibf/in ² (psi)
Noise						
Cubic Foot	ft3	x 0,02832	= m ³	(Cubic Metre)	x 35,31	= ft3
Cubic Yard	yd3	x 0,7646	= m ³	(Cubic Metre)	x 1,308	= yd3
Cycle Strength						
Pound Foot	lb ft	x 0,1383	= kgm	(Kilogramme Metre)	x 7,233	= lb ft
Kilogramme Metre	kgm	x 9,81	= Nm	(Newton Metre)	x 0,102	= m kg

TIRE DEFINITION CODE

Service		Tread Types	
Code	Type Of Service	Code	Tread Type
C	Compactor	C - 1	Smooth
		C - 2	Grooved
E	Earthmover	E - 1	Rib
		E - 2	Traction
		E - 3	Rock
		E - 4	Rock Deep Tread
		E - 7	Flotation
G	Grader	G - 1	Rib
		G - 2	Traction
		G - 3	Rock
L	Loader and Dozer	L - 2	Traction
		L - 3	Rock
		L - 3S	Smooth
		L - 4	Rock Deep Tread
		L - 4S	Smooth Deep Tread
		L - 5	Rock Extra Deep Tread
		L - 5S	Smooth Extra Deep Tread



LOAD SPEED INDEX

LI	kg	LI	kg	LI	kg	LI	kg	LI	kg
120	1400	150	3350	180	8000	210	19000	240	45000
121	1450	151	3450	181	8250	211	19500	241	46250
122	1500	152	3550	182	8500	212	20000	242	47500
123	1550	153	3650	183	8750	213	20600	243	48750
124	1600	154	3750	184	9000	214	21200	244	50000
125	1650	155	3875	185	9250	215	21800	245	51500
126	1700	156	4000	186	9500	216	22400	246	53000
127	1750	157	4125	187	9750	217	23000	247	54500
128	1800	158	4250	188	10000	218	23600	248	56000
129	1850	159	4375	189	10300	219	24300	249	58000
130	1900	160	4500	190	10600	220	25000	250	60000
131	1950	161	4625	191	10900	221	25750	251	61500
132	2000	162	4750	192	11200	222	26500	252	63000
133	2060	163	4875	193	11500	223	27250	253	65000
134	2120	164	5000	194	11800	224	28000	254	67000
135	2180	165	5150	195	12150	225	29000	255	69000
136	2240	166	5300	196	12500	226	30000	256	71000
137	2300	167	5450	197	12850	227	30750	257	73000
138	2360	168	5600	198	13200	228	31500	258	75000
139	2430	169	5800	199	13600	229	32500	259	77500
140	2500	170	6000	200	14000	230	33500	260	80000
141	2575	171	6150	201	14500	231	34500	261	82500
142	2650	172	6300	202	15000	232	35500	262	85000
143	2725	173	6500	203	15500	233	36500	263	87500
144	2800	174	6700	204	16000	234	37500	264	90000
145	2900	175	6900	205	16500	235	38750	265	92500
146	3000	176	7100	206	17000	236	40000	266	95000
147	3075	177	7300	207	17500	237	41250	267	97500
148	3150	178	7500	208	18000	238	42250	268	100000
149	3250	179	7750	209	18500	239	43750	269	103000

(LI) : Load Index

Speed Category

Symbol	A2	A8	B	C	D	E
Speed km/h	10	40	50	60	65	70

Sample Tire Marking

16.00 - 25 NB60 E3 32 PR TL 177 B

(This tire can bear 7300 kg load at the speed of 50 km/h.)



SKIDSTEER
SM 135

 **starmaxx**

SMF 20

Powerfull nylon cord body, strong heel construction provide high performance and durability against impacts.



TIRE SIZE	PR	TT/TL	LOAD INDEX	SPEED SYMBOL	INFLATING PRESSURE (psi)	RIM		INFLATED DIMENSIONS (NO LOAD)		LOAD CAPACITTY PER TIRE (KG)
						RECOM. (INCHES)	PERMITTED (INCHES)	SECTION WIDTH MIN-MAX	RADIUS (MM)	
23x5-13	10	TT	121	A5	116	3,75P	-	155	635	1150
4.00-8	8	TT	94	A5	131	31/4I	3.00D	115	414	670
5.00-8	8	TT	106	A5	120	31/4I	-	132	132	950
5.00-8	10	TT	111	A5	145	3.00D	3 1/4 I	132	467	1090
18x7-8	16	TT	125	A5	145	4.33R	-	173	462	1650
6.00-9	12	TT	121	A5	145	4.00E	-	160	540	1450
21x8-9	14	TT	131	A5	131	6.00E	-	200	535	1950
6.50-10	12	TT	125	A5	131	5.00F	5.50F	177	588	1650
23x9-10	20	TT	142	A5	145	6.50F	-	225	595	2650
7.00-12	14	TT	134	A5	131	5.00S	-	192	672	2120
27x10-12	14	TT	143	A5	102	8.00G	-	255	690	2725
8.15-15	14	TT	146	A5	145	7.0	-	216	707	3000
8.25-15	16	TT	152	A5	134	6.5	7	234	836	3550



SMF 30

High traction tread structure, durable against impacts.
A high performance tire with strong nylon structure and reinforced bead design.



TIRE SIZE	PR	TT/TL	LOAD INDEX	SPEED SYMBOL	INFLATING PRESSURE (psi)	RIM		INFLATED DIMENSIONS (NO LOAD)		LOAD CAPACITY PER TIRE (KG)
						RECOM. (INCHES)	PERMITTED (INCHES)	SECTION WIDTH MIN-MAX	RADIUS (MM)	
4.00-8	8	TT	94	A5	131	3.25	3.00D, 3 1/4I	115	414	670
5.00-8	10	TT	111	A5	145	3.00D	3.25I, 3.75I	132	467	1090
18X7-8	16	TT	125	A5	145	4.33R	-	173	462	1650
16X6-8	16	TT	113	A5	145	4.33	4.33R	152	425	1150
6.00-9	12	TT	121	A5	145	4.00E	-	160	540	1450
21X8-9	14	TT	131	A5	131	6	6.00E	200	535	1950
6.50-10	12	TT	125	A5	131	5.00F	5.50F	177	588	1650
23X9-10	20	TT	142	A5	145	6.5	6.50F	225	595	2650
7.00-12	14	TT	134	A5	131	5.00S	-	192	672	2120
23X5-(13)	10	TT	121	A5	116	3,75	3.75P	155	635	1450
7.50-15	14	TT	144	A5	135	6.0, 6.00S	5.5, 6.5	212	772	2800
8.15-15	14	TT	146	A5	145	7	-	216	707	3000
250-15	20	TT	155	A5	145	7.0, 7.5	-	250	735	3875
300-15	20	TT	164	A5	131	8.0,	-	300	840	5000

*23x10-12, 27x10-12 SIZES ARE UNDERDEVELOPMENT NOW.



SMF 40

High traction tread structure, durable against impacts. A high performance tire with strong nylon structure and reinforced bead design.



TIRE SIZE	PR	TT/TL	LOAD INDEX	SPEED SYMBOL	INFLATING PRESSURE (psi)	RIM		INFLATED DIMENSIONS (NO LOAD)		LOAD CAPACITY PER TIRE (KG)
						RECOM. (INCHES)	PERMITTED (INCHES)	SECTION WIDTH MIN-MAX	RADIUS (MM)	
6.00-9	12	TT	121	A5	145	4.00E	-	160	540	1450
6.50-10	12	TT	125	A5	131	5.00F	5.50F	177	588	1650
7.00-12	14	TT	134	A5	131	5.00S	-	192	672	2120
8.15-15	14	TT	146	A5	145	7.0	-	216	707	3000
8.25-15	16	TT	152	A5	134	6.5	7	234	836	3550



SM S2

High traction tread structure, durable against impacts.
A high performance tire with strong nylon structure and reinforced bead design.



TIRE SIZE	PR	TT/TL	LOAD INDEX	SPEED SYMBOL	RIM		INFLATED DIMENSIONS (NO LOAD)		INFLATED DIMENSIONS (W/LOAD)		TREAD DEPTH (MM)	INFLATING PRESSURE (psi/bar)	LOAD CAPACITY PER TIRE (KG)	
					RECOM. (INCHES)	PERMITTED (INCHES)	SECTION WIDTH MIN-MAX	OUTER DIAMETER (MM)	DYNAMIC RADIUS CIRCLE (MM)	STATIC LOADED RADIUS (MM)			Speed (KM/H)	
													40	50
23.1-26	10	TT	158	A8	DW20	-	587	1580	4582	708	27	25	4250	3870
23.1-26	12	TL	162	A8	DW20	-	587	1580	4582	708	27	28	4750	4325



SM C1

Optimized tread curve provides smoothed rubber tread trace and excellent wear performance.

Strong nylon carcass and special tread mixture provides maximum performance on cool and warm asphalt during road constructions.



TIRE SIZE	PR	TT/ TL	LOAD INDEX	SPEED SYMBOL	RIM		INFLATED DIMENSIONS (NO LOAD)		INFLATED DIMENSIONS (W/ LOAD)		TREAD DEPTH (MM)	INFLATING PRESSURE (psi/bar)	LOAD CAPACITY PER TIRE (KG)
					RECOM. (INCHES)	PERMITTED (INCHES)	SECTION WIDTH MIN-MAX	OUTER DIAMETER (MM)	DYNAMIC RADIUS CIRCLE (MM)	STATIC LOADED RADIUS (MM)			
11.00-20	14	TT	165	A2	9.0,9.00V	8.0V,8.5,10.0	326	1048	3039	476	-	94	5120
13.0/80R20	-	TL	164	A3	8.0,B8.0,8.0V	7.33V,7.5,B7.5,7.5V,8.37V	291	1070	3103	785	-	131	5000

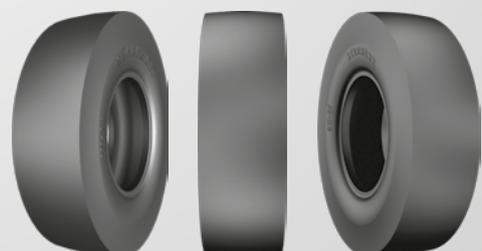

SM 135

Provides powerful traction and good gripping on muddy and rough surfaces. Appropriate tread pattern provides easy control. Resistant to problems such as cracks, ruptures and stone cuts. Extra thick rubber part in the center of the tread provides long wear life and comfortable drive on hard surfaces. Deep grooved unidirectional pattern provides powerful traction and self cleaning feature under all conditions. Strong off-road service mixture provides resistance to cuts, disintegrations, tears and wear. Strong nylon, cord and body structure provides high resistance to impacts and durability.



TIRE SIZE	PR	TT/TL	LOAD INDEX	SPEED SYMBOL	RIM		INFLATED DIMENSIONS (NO LOAD)		INFLATED DIMENSIONS (W/LOAD)		TREAD DEPTH (MM)	INFLATING PRESSURE (psi/bar)	LOAD CAPACITY PER TIRE (KG)				
					RECOM. (INCHES)	PERMITTED (INCHES)	SECTION WIDTH MIN-MAX	OUTER DIAMETER (MM)	DYNAMIC RADIUS CIRCLE (MM)	STATIC LOADED RADIUS (MM)			Speed (KM/H)				
													10	15	20	25	30
10-16.5NHS	12	TL	138	A3	8,25	-	260	799	2318	365	34	90	2525	2360	2170	2005	1840
12-16.5NHS	14	TL	147	A3	9,75	-	307	870	2520	394	34	90	3290	3075	2830	2610	2400



Stx ND31

Stx ND31 is a radial multi-purpose tire, developed for construction equipment to be used in the areas of agriculture and construction, providing excellent traction, longevity, resistance to damage and high carrying capacity. Stx ND31 is the right response for all agro-industrial heavy-duty needs and suitable for all digging and loading operations on vehicles such as telehandlers, compact loaders and backhoe loaders.



TIRE SIZE	TT/TL	LOAD INDEX	SPEED SYMBOL	RIM		INFLATED DIMENSIONS (NO LOAD)		INFLATED DIMENSIONS (W/LOAD)		TREAD DEPTH (MM)	INFLATING PRESSURE (psi/bar)	LOAD CAPACITY PER TIRE (KG)			
				RECOM. (INCHES)	PERMITTED (INCHES)	SECTION WIDTH MIN-MAX	OUTER DIAMETER (MM)	DYNAMIC RADIUS CIRCLE (MM)	STATIC LOADED RADIUS (MM)			Speed (KM/H)			
												10	25	30	40
340/80R18 (12.5/80 R18)	TL	143	A8/B	11	W10, 11SDC, W11, 12, 12SDC	345	995	2975	446	30	58	3405	3025	2915	2725
440/80R28 (16.9 R28)	TL	156	A8/B	DW14L	DW13, DW13L DW15L	441	1415	4215	636	35	46	5000	4440	4280	4000
405/70 R20 (16.0/70 R20)	TL	149	A8/B	13	12SDC, 13SDC, 14	414	1070	3200	480	30	58	4065	3610	3480	3250
460/70 R24 (17.5L R24)	TL	159	A8/B	DW15L	DW14L DW16L	453	1251	3740	562	36	58	5470	4855	4680	4375
400/70 R20 (16.0/70 R20)	TL	149	A8/B	13	12SDC, 13SDC, 14	414	1070	3200	480	30	58	4065	3610	3480	3250



TR 45

It is developed for 2WD front axles of tractors and compact earthmovers for the purpose of using in agricultural areas and worksites. Moreover, it is multi-purpose, low-profile tyre that can be used on trailers for on road or off road. Low-profile height and strong carcass structure provides excellent balance, maneuverability and driver comfort. It provides resistance and longevity against to tears and wears on hard soil, asphalt, and concrete with its specially formulated tread compound and reinforced carcass structure.



TIRE SIZE	TT/TL	LOAD INDEX	SPEED SYMBOL	RIM		INFLATED DIMENSIONS (NO LOAD)		INFLATED DIMENSIONS (W/LOAD)		INFLATING PRESSURE (psi/bar)	LOAD CAPACITY PER TIRE (KG)	
				RECOM. (INCHES)	PERMITTED (INCHES)	SECTION WIDTH MIN-MAX	OUTER DIAMETER (MM)	DYNAMIC RADIUS CIRCLE (MM)	STATIC LOADED RADIUS (MM)		Speed (KM/H)	
											30	40
11L-16 SL	TL	116	A8	W8L , 8LB	W10L, 10LB	284	800	2368	371	64 / 4,4	1385	1250



TR 60



Provides ultimate durability with reinforced structure and durable cords.
 A long-life tire, absorbing the impacts and durable against drills.
 Improved rubber structure provides smooth drive.
 Driving on any sand surface with wide and no-sand-holding pattern.
 High traction with special tread design.
 Wide shoulders provides stability on the road.
 No-sand-holding property thanks to the middle channel on the pattern.
 Special bead design provides stability on the rim and protection against bead wear.

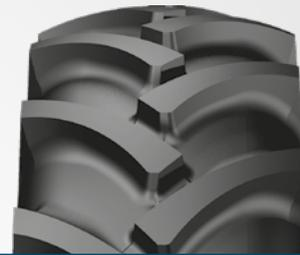

TIRE SIZE	PR	TT/ TL	LOAD INDEX		SPEED SYMBOL	RIM		INFLATED DIMENSIONS (NO LOAD)		INFLATED DIMENSIONS (W/ LOAD)		TREAD DEPTH (MM)	INFLATING PRESSURE (psi/bar)	LOAD CAPACITY PER TIRE (FREE ROLLING SPEED,KM/H)	LOAD CAPACITY PER TIRE (DRIVE WHEEL SPEED,KM/H)
			FREE ROLLING (KG)	DRIVE WHEEL (KG)		RECOM. (INCHES)	PERMITTED (INCHES)	SECTION WIDTH MIN-MAX	OUTER DIAMETER (MM)	DYNAMIC RADIUS CIRCLE (MM)	STATIC LOADED RADIUS (MM)			40	40
15.5/80-24	12	TL	157	145	A8	W12	W13, W14L	394	1262	3660	573	34	43	4125	2900
15.5/80-24	16	TL	163	151	A8	W12	W13, W14L	394	1262	3660	573	34	58	4875	3450



SM 5



Deep grooved pattern provides high self cleaning feature.

Extra rubber in its compound provides long wear life and comfortable drive on hard surfaces.

Thanks to its multi-purpose gum and rubber structure, designed for small loaders with back-hoe and tele-handlers which are used on soft surfaces where extra traction power is needed, it is resistant to cuts, ruptures and cracks; and provides a long driving life and a comfortable drive.

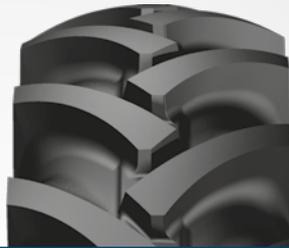

TIRE SIZE	PR	TT/ TL	LOAD INDEX	SPEED SYMBOL	RIM		INFLATED DIMENSIONS (NO LOAD)		INFLATED DIMENSIONS (W/ LOAD)		TREAD DEPTH (MM)	INFLATING PRESSURE (psi/bar)	LOAD CAPACITY PER TIRE (KG)					
					RECOM. (INCHES)	PERMITTED (INCHES)	SECTION WIDTH MIN-MAX	OUTER DIAMETER (MM)	DYNAMIC RADIUS CIRCLE (MM)	STATIC LOADED RADIUS (MM)			Speed (KM/H)					
													10	15	20	25	30	40
18.4-26	14	TL	145	A8	W16L	W15L	467	1450	4321	647	38	40	4060	3857	3654	3451	3248	2900
16.9-30	14	TL	153	A8	W15L	W14L	429	1485	4307	677	39	42	5250	5000	4700	4450	4200	3650



SM PL



Strengthened wide block treads and shoulder structure grips the surface and provides maximum traction performance. Optimized distance between blocks provides self cleaning on muddy surfaces without any traction loss. Pattern blocks are designed not to be deformed during short distance turns.



TIRE SIZE	PR	TT/TL	LOAD INDEX	SPEED SYMBOL	RIM		INFLATED DIMENSIONS (NO LOAD)		INFLATED DIMENSIONS (W/ LOAD)		TREAD DEPTH (MM)	INFLATING PRESSURE (psi/bar)	LOAD CAPACITY PER TIRE (KG)							
					RECOM. (INCHES)	PERMITTED (INCHES)	SECTION WIDTH MIN-MAX	OUTER DIAMETER (MM)	DYNAMIC RADIUS CIRCLE (MM)	STATIC LOADED RADIUS (MM)			Speed (KM/H)							
													10	15	20	25	30	35	40	50
15.5-25	12	TL	149	B	12.00/1.3	12.00/1.3 (DC) (1)	394	1277	3703	581	25	36	-	3640	3575	3510	3445	3380	3350	3250



SM 38



Resistant against cut and tears with bidirectional pattern and reinforced rubber structure.
 Resistant against lateral impacts and cuts with extra reinforced rubber structure, especially on rocky surfaces



TIRE SIZE	PR	TT/TL	LOAD INDEX		SPEED SYMBOL	RIM		INFLATED DIMENSIONS (NO LOAD)		INFLATED DIMENSIONS (W/ LOAD)		TREAD DEPTH (MM)	INFLATING PRESSURE (psi/bar)	LOAD CAPACITY PER TIRE (SINGLE AXE USAGE)	LOAD CAPACITY PER TIRE (DOUBLE AXE USAGE)
			SINGLE AXE USAGE	DOUBLE AXE USAGE		RECOM. (INCHES)	PERMITTED (INCHES)	SECTION WIDTH MIN-MAX	OUTER DIAMETER (MM)	DYNAMIC RADIUS CIRCLE (MM)	STATIC LOADED RADIUS (MM)			50	50
7.50-20	10	TT	123	122	B	5.50F	6.00F	214	904	2622	417	15	58	1550	1500
9.00-20	14	TT	140	137	B	7.00	6.5 ; 7.5	230	1036	3004	471	20	62	2500	2300
10.00-20	16	TT	146	143	B	7.50	7.0 ; 8.0	270	1060	3074	481	22	109	3000	2725



SM 135

SMF 40

SM F20

SM S2

SM 38

SM 60

SM 70



 **starmaxx**



Stx L42

Stx L42 is an entire steel radial heavy duty vehicle tire that has resistance to tears and wears in worksites and on challenging roads in all kinds of weather conditions. Specially formulated tread composition and whole steel carcass structure of Stx L42 offer longevity.



TIRE SIZE	PR	TT/TL	LOAD INDEX	SPEED SYMBOL	RIM		INFLATED DIMENSIONS (NO LOAD)		INFLATED DIMENSIONS (W/LOAD)		TREAD DEPTH (MM)	INFLATING PRESSURE (psi/bar)	LOAD CAPACITY PER TIRE (KG)			
					RECOM. (INCHES)	PERMITTED (INCHES)	SECTION WIDTH MIN-MAX	OUTER DIAMETER (MM)	DYNAMIC RADIUS CIRCLE (MM)	STATIC LOADED RADIUS (MM)			Speed (KM/H)			
													10	30	40	50
14.00 R24	*	TL	153	A8	8.00 TG SDC	9.00/1.5 (DC) ; 10.00/VA SDC	1348	364	3909	608	26	54	3650	3650	3650	3322

*:16PR



SG 200

Longer life with more solid tread center; higher cracking resistance with curved tread structure. Strengthened tread blocks provide higher power transfer and lower fuel consumption. Extra rubber in its compound provides longer wear life and tread bottom crack/fatigue resistance

Special tread compound provides a longer life and higher cut resistance. Strengthened bead and body structure provides retreadability. Extra impact layers for absorption first impacts.

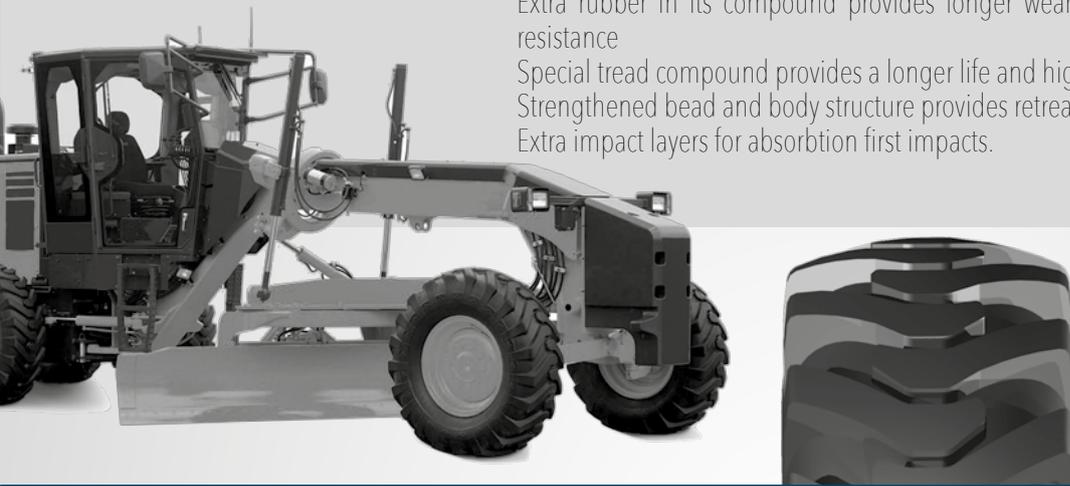

TIRE SIZE	PR	TT/TL	LOAD INDEX	SPEED SYMBOL	RIM		INFLATED DIMENSIONS (NO LOAD)		INFLATED DIMENSIONS (W/ LOAD)		TREAD DEPTH (MM)	INFLATING PRESSURE (psi/bar)	LOAD CAPACITY PER TIRE (KG)						
					RECOM. (INCHES)	PERMITTED (INCHES)	SECTION WIDTH MIN-MAX	OUTER DIAMETER (MM)	DYNAMIC RADIUS CIRCLE (MM)	STATIC LOADED RADIUS (MM)			Speed (KM/H)						
													15	20	25	30	35	40	50
13.00-24	12	TT	143	A8	8.00 TG SDC	9.00/1.5 (DC) (1) ; 10.00/VA SDC	333	1278	3706	579	25	44	3080	2970	2890	2835	2780	2725	2480
13.00-24	12	TL	143	A8	8.00 TG SDC	9.00/1.5 (DC) (1) ; 10.00/VA SDC	333	1278	3706	579	25	44	3080	2970	2890	2835	2780	2725	2480
13.00-24	16	TT	151	A8	8.00 TG SDC	9.00/1.5 (DC) ; 10.00/VA SDC	333	1278	3706	579	25	58	3450	3450	3450	3450	-	3450	3140
13.00-24	16	TL	151	A8	8.00 TG SDC	9.00/1.5 (DC) ; 10.00/VA SDC	333	1278	3706	579	25	58	3450	3450	3450	3450	-	3450	3140
14.00-24	16	TT	153	A8	8.00 TG SDC	9.00/1.5 (DC) (1) ; 10.00/VA SDC	362	1348	3909	608	26	54	4124,5	3980	3870	3800	3725	3650	3325
14.00-24	16	TL	153	A8	8.00 TG SDC	9.00/1.5 (DC) (1) ; 10.00/VA SDC	362	1348	3909	608	26	54	4124,5	3980	3870	3800	3725	3650	3325



SG 300

Longer life with more solid tread center; higher cracking resistance with curved tread structure. Strengthened tread blocks provide higher power transfer and lower fuel consumption. Extra rubber in its compound provides longer wear life and tread bottom crack/fatigue resistance.
 Special tread compound provides a longer life and higher cut resistance. Strengthened bead and body structure provides retreadability. Extra impact layers for absorption first impacts.

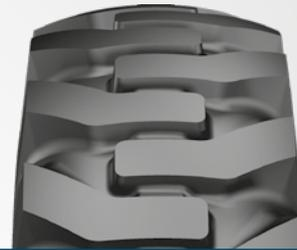
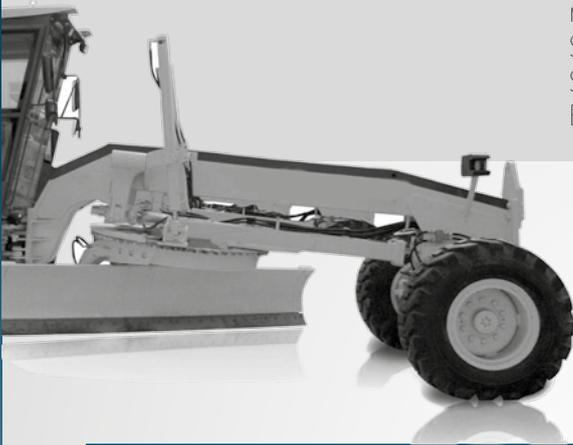

TIRE SIZE	PR	TT/ TL	LOAD INDEX	SPEED SYMBOL	RIM		INFLATED DIMENSIONS (NO LOAD)		INFLATED DIMENSIONS (W/ LOAD)		TREAD DEPTH (MM)	INFLATING PRESSURE (psi/bar)	LOAD CAPACITY PER TIRE (KG)						
					RECOM. (INCHES)	PERMITTED (INCHES)	SECTION WIDTH MIN-MAX	OUTER DIAMETER (MM)	DYNAMIC RADIUS CIRCLE (MM)	STATIC LOADED RADIUS (MM)			Speed (KM/H)						
													15	20	25	30	35	40	50
16.00-24	16	TL	160	A8	10.00VA SDC	-	427	1459	4231	653	32	47	5085	4905	4770	4680	4590	4500	4095



Stx L31 (E3-L3)

Entire steel radial OTR tire has resistance to all kind of damage, designed to use on loaders and articulated trucks. Efficient self-clean feature thanks to special grooving geometry. Inter-located blocks protect integrity of blocks on all kind of surfaces. Specially designed tread provides longevity and resists wear, cuts and heat.



TIRE SIZE	PR	TT/TL	LOAD INDEX	SPEED SYMBOL	RIM		INFLATED DIMENSIONS (NO LOAD)		INFLATED DIMENSIONS (W/LOAD)		TREAD DEPTH (MM)	INFLATING PRESSURE (psi/bar)	LOAD CAPACITY PER TIRE (KG)
					RECOM. (INCHES)	PERMITTED (INCHES)	SECTION WIDTH MIN-MAX	OUTER DIAMETER (MM)	DYNAMIC RADIUS CIRCLE (MM)	STATIC LOADED RADIUS (MM)			Speed (KM/H)
													10
26.5 R25	**	TL	193	B	22,00/ 3.0	22,00/ 3.0 IF	705	1755	5195	772	44	83	18500

**32PR



SM 57 (E3)



Heat resistant tread rubber compound reduces warming up and increases durability.
 Heavy duty tire, designed for high front and back traction performance.
 Provides perfect traction on soft and muddy surfaces. Self cleaning feature provides lower warming up.
 Special tread pattern design provides high resistance to damage, wear and cut.



TIRE SIZE	PR	TT/ TL	LOAD INDEX	SPEED SYMBOL	RIM		INFLATED DIMENSIONS (NO LOAD)		INFLATED DIMENSIONS (W/ LOAD)		TREAD DEPTH (MM)	INFLATING PRESSURE (psi/bar)	LOAD CAPACITY PER TIRE (KG)						
					RECOM. (INCHES)	PERMITTED (INCHES)	SECTION WIDTH MIN-MAX	OUTER DIAMETER (MM)	DYNAMIC RADIUS CIRCLE (MM)	STATIC LOADED RADIUS (MM)			Speed (KM/H)						
													30	40	45	50	55	60	65
14.00-24	16	TT	153	D	10.00 VA	10.00 ; 9.00 ; 9.00V	375	1360	3944	613	24	61	4455	4345	4310	4235,4	4125	3945	3620
14.00-24	20	TT	157	D	10.00 VA	10.00 ; 9.00 ; 9.00V	375	1360	3944	613	24	69	5045	4920	4880	4800	4675	4470	4100
14.00-24	20	TL	157	D	10.00 VA	10.00 ; 9.00 ; 9.00V	375	1360	3944	613	24	69	5045	4920	4880	4800	4675	4470	4100
14.00-24	24	TT	160	D	10.00 VA	10.00 ; 9.00 ; 9.00V	375	1360	3944	613	24	83	5570	5435	5390	5300,1	5165	4940	4530
14.00-24	28	TT	168	D	10.00 VA	10.00 ; 9.00 ; 9.00V	375	1360	3944	613	24	94	6890	6720	6665	6550	6385	6105	5600
14.00-24	28	TL	168	D	10.00 VA	10.00 ; 9.00 ; 9.00V	375	1360	3944	613	24	94	6890	6720	6665	6550	6385	6105	5600
14.00-24	32	TT	170	D	10.00 VA	10.00 ; 9.00 ; 9.00V	375	1360	3944	613	24	105	7380	7200	7140	7020	6840	6540	6000
14.00-24	32	TL	170	D	10.00 VA	10.00 ; 9.00 ; 9.00V	375	1360	3944	613	24	105	7380	7200	7140	7020	6840	6540	6000



SM 60 (E3)

Heat resistant tread rubber compound reduces warming up and increases durability.
 Long lasting heavy duty tire due to its special nylon cord carcass structure.
 Heavy duty tire with high wear resistance, designed for working under severe conditions.

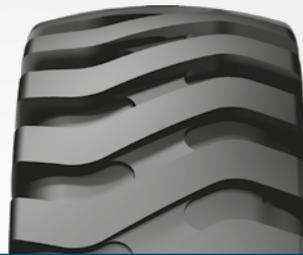

TIRE SIZE	PR	TT/TL	LOAD INDEX	SPEED SYMBOL	RIM		INFLATED DIMENSIONS (NO LOAD)		INFLATED DIMENSIONS (W/ LOAD)		TREAD DEPTH (MM)	INFLATING PRESSURE (psi/bar)	LOAD CAPACITY PER TIRE (KG)						
					RECOM. (INCHES)	PERMITTED (INCHES)	SECTION WIDTH MIN-MAX	OUTER DIAMETER (MM)	DYNAMIC RADIUS CIRCLE (MM)	STATIC LOADED RADIUS (MM)			Speed (KM/H)						
													15	20	25	30	35	40	50
16.00-25	32	TL	177	B	11.25/2.0	11.25/2.0 IF (2); 13.00/2.0	432	1493	4330	670	31	94	8175	8030	7885	7740	7595	7520	7300
18.00-25	32	TL	183	B	13.00/2.5	13.00(2.5 IF (2); 15.00/2.5	498	1615	4684	719	34	83	9800	9625	9450	9275	9100	9015	8750
18.00-25	40	TL	187	B	13.00/2.5	13.00(2.5 IF (2); 15.00/2.5	498	1615	4684	719	34	102	10920	10725	10530	10335	10140	10045	9750
18.00-33	32	TL	188	B	13.00/2.5	-	498	1818	5272	821	37	83	11200	11000	10800	10600	10400	10300	10000



Stx L31 (L3)

Entire steel radial OTR tire has resistance to all kind of damage, designed to use on loaders and articulated trucks. Efficient self-clean feature thanks to special grooving geometry. Inter-located blocks protect integrity of blocks on all kind of surfaces. Specially designed tread provides longevity and resists wear, cuts and heat.

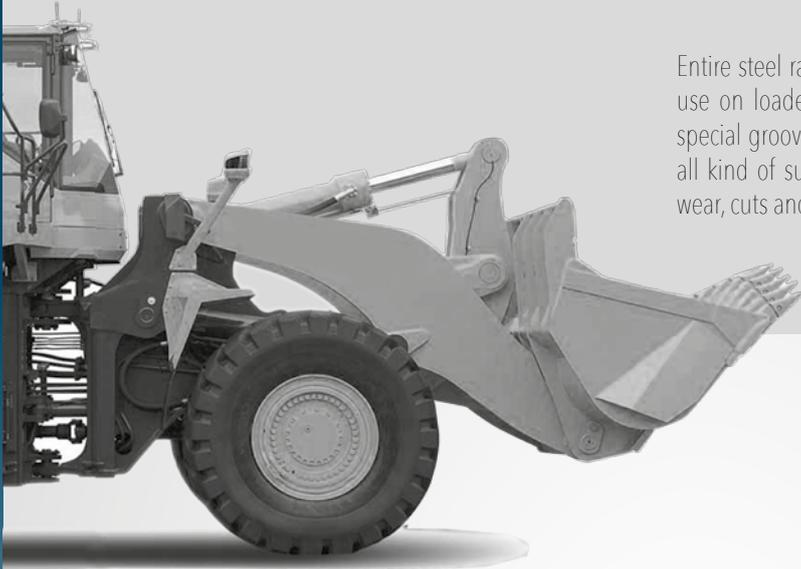

TIRE SIZE	PR	TT/TL	LOAD INDEX	SPEED SYMBOL	RIM		INFLATED DIMENSIONS (NO LOAD)		INFLATED DIMENSIONS (W/LOAD)		TREAD DEPTH (MM)	INFLATING PRESSURE (psi/bar)	LOAD CAPACITY PER TIRE (KG)
					RECOM. (INCHES)	PERMITTED (INCHES)	SECTION WIDTH MIN-MAX	OUTER DIAMETER (MM)	DYNAMIC RADIUS CIRCLE (MM)	STATIC LOADED RADIUS (MM)			Speed (KM/H)
26.5 R25	**	TL	209	A2	22.00/3.0	22.00/3.0 IF	705	1755	5195	772	44	83	18500

** : 32PR



SM 57 (L3)



Special tread design provides endurance against impacts and high resistance for wear and cut.

Long lasting tire due to its strong rubber and cord structure.

Designed for small and medium sized loaders, providing high traction and grip on rough surfaces.

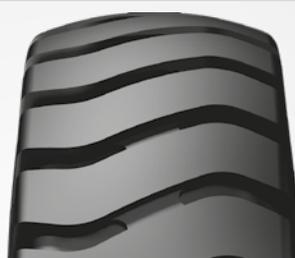

TIRE SIZE	PR	TT/TL	LOAD INDEX	SPEED SYMBOL	RIM		INFLATED DIMENSIONS (NO LOAD)		INFLATED DIMENSIONS (W/ LOAD)		TREAD DEPTH (MM)	INFLATING PRESSURE (psi/bar)	LOAD CAPACITY PER TIRE (KG)			LOAD CAPACITY PER TIRE (KG)		
					RECOM. (INCHES)	PERMITTED (INCHES)	SECTION WIDTH MIN-MAX	OUTER DIAMETER (MM)	DYNAMIC RADIUS CIRCLE (MM)	STATIC LOADED RADIUS (MM)			OFF ROAD PURPOSES			HARD IMPROVED SURFACE		
													STATIC	10 KM/H **	25 KM/H	STATIC	5 KM/H	10 KM/H **
17.5-25 12 TL 171 A2	14.00/1.5	14.00/1.3 (1); 13.00/1.4 (DC)	445	1348	3909	610	26	51	9840	6150	5230	11070	8920	8305				
17.5-25 16 TT 177 A2	14.00/1.5	14.00/1.3 (1); 13.00/1.4 (DC)	445	1348	3909	610	26	69	11680	7300	6205	13140	10585	9855				
17.5-25 16 TL 177 A2	14.00/1.5	14.00/1.3 (1); 13.00/1.4 (DC)	445	1348	3909	610	26	69	11680	7300	6205	13140	10585	9855				
17.5-25 20 TL 181 A2	14.00/1.5	14.00/1.3 (1); 13.00/1.4 (DC)	445	1348	3909	610	26	83	13200	8250	7015	14850	11965	11140				
20.5-25 16 TL 181 A2	17.00/1.7	17.00/2.0 IF (2)	520	1492	4327	669	30	51	13200	8250	7015	14850	11965	11140				
20.5-25 20 TL 181 A2	17.00/1.7	17.00/2.0 IF (2)	520	1492	4327	669	30	65	15200	9500	8075	17100	13775	12825				
20.5-25 24 TL 186 A2	17.00/1.7	17.00/2.0 IF (2)	520	1492	4689	669	30	65	15200	9500	8075	17100	13775	12825				
23.5-25 20 TL 191 A2	19.50/2.5	19.50/2.5 IF (2)	597	1617	4689	720	35	54	17440	10900	9265	19620	15805	14715				
23.5-25 24 TL 196 A2	19.50/2.5	19.50/2.5 IF (2)	597	1617	4689	720	35	69	20000	12500	10625	22500	18125	16875				



SM 60 (L3)



Nondirectional tread design, reinforced rubber structure provides ability to work under severe conditions and increases cut and break-off resistance. Extra rubber compound designed for hard and rocky terrains provides resistance to side-wall damages and cuts.

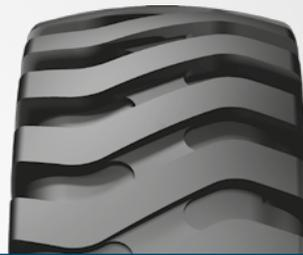

TIRE SIZE	PR	TT/TL	LOAD INDEX	SPEED SYMBOL	RIM		INFLATED DIMENSIONS (NO LOAD)		INFLATED DIMENSIONS (W/ LOAD)		TREAD DEPTH (MM)	INFLATING PRESSURE (psi/bar)	LOAD CAPACITY PER TIRE (KG)			LOAD CAPACITY PER TIRE (KG)		
					RECOM. (INCHES)	PERMITTED (INCHES)	SECTION WIDTH MIN-MAX	OUTER DIAMETER (MM)	DYNAMIC RADIUS CIRCLE (MM)	STATIC LOADED RADIUS (MM)			OFF ROAD PURPOSES			HARD IMPROVED SURFACE		
													STATIC	10 KM/H **	25 KM/H	STATIC	5 KM/H	10 KM/H **
17.5-25	16	TL	177	A2	14.00/1.5	14.00/1.3 (1) ; 13.00/1.4 (DC)	445	1348	3909	610	26	69	16000	10000	8500	18000	14500	13500
20.5-25	20	TL	186	A2	17.00/2.0	17.00/2.0 IF (2)	520	1492	4327	669	30	65	15200	9500	8075	17100	13775	12825
23.5-25	20	TL	191	A2	19.50/2.5	19.50/2.5 IF (2)	597	1617	4689	720	35	54	17440	10900	9265	19620	15805	14715
23.5-25	24	TL	196	A2	19.50/2.5	19.50/2.5 IF (2)	597	1617	4689	720	35	69	20000	12500	10625	22500	18125	16875
26.5-25	28	TL	203	A2	22.00/3.0	22.00/3.0 IF (2)	673	1750	5075	775	39	69	24800	15500	13175	27900	22475	20925
26.5-25	32	TL	206	A2	22.00/3.0	22.00/3.0 IF (2)	673	1750	5075	775	39	80	27200	17000	14450	30600	24650	22950
29.5-25	28	TL	207	A2	25.00/3.5	25.00/3.5 IF (2)	750	1873	5432	825	44	62	28000	17500	14875	31500	25375	23625
29.5-25	32	TL	207	A2	25.00/3.5	25.00/3.5 IF (2)	750	1873	5432	825	44	62	28000	17500	14875	31500	25375	23625



SM 70 (L3)

Cut resistant special tread compound reduces damages and cuts in case of over usage.
 Strong loader-dozer design provides safe drive and easy rotation ability.
 Appropriate for usage on muddy and sandy surfaces with high traction.
 High traction, balanced steering and high surface-grip performance.

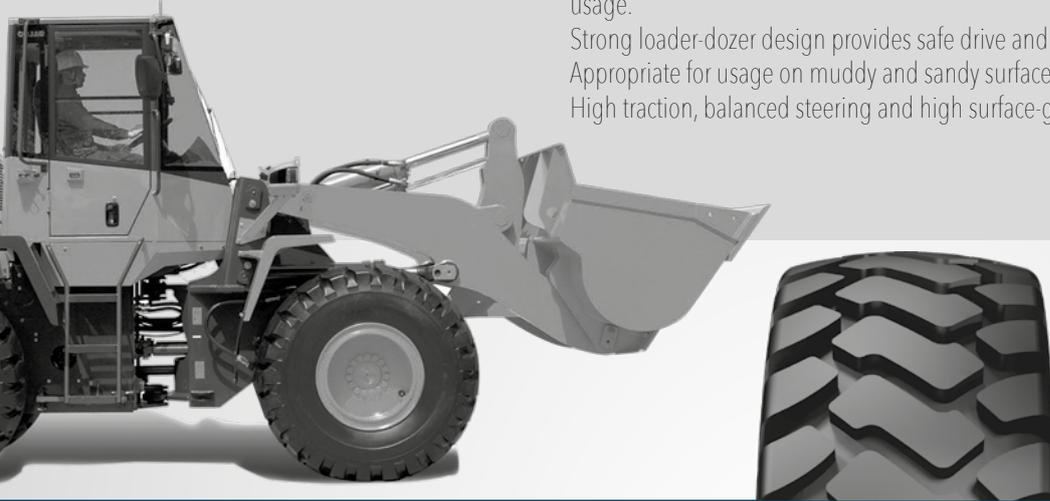

TIRE SIZE	PR	TT/ TL	LOAD INDEX	SPEED SYMBOL	RIM		INFLATED DIMENSIONS (NO LOAD)		INFLATED DIMENSIONS (W/ LOAD)		TREAD DEPTH (MM)	INFLATING PRESSURE (psi/bar)	LOAD CAPACITY PER TIRE (KG)			LOAD CAPACITY PER TIRE (KG)		
					RECOM. (INCHES)	PERMITTED (INCHES)	SECTION WIDTH MIN-MAX	OUTER DIAMETER (MM)	DYNAMIC RADIUS CIRCLE (MM)	STATIC LOADED RADIUS (MM)			OFF ROAD PURPOSES			HARD IMPROVED SURFACE		
													STATIC	10 KM/H **	25 KM/H	STATIC	5 KM/H	10 KM/H **
15.5-25	12	TL	168	A2	12.00/1.3	12.00/1.3 (DC)(1)	394	1277	3703	581	25	58	8960	5600	4760	10080	8120	7560
17.5-25	16	TL	177	A2	14.00/1.5	14.00/1.3 (1) ; 13.00/1.4 (DC)	445	1348	3909	610	26	69	11680	7300	6205	13140	10585	9855
20.5-25	20	TL	186	A2	17.00/2.0	17.00/2.0 IF (2)	520	1492	4327	669	30	65	15200	9500	8075	17100	13775	12825
23.5-25	20	TL	191	A2	19.50/2.5	19.50/2.5 IF (2)	597	1617	4689	720	35	54	17440	10900	9265	19620	15805	14715
23.5-25	24	TL	196	A2	19.50/2.5	19.50/2.5 IF (2)	597	1617	4689	720	35	69	20000	12500	10625	22500	18125	16875
26.5-25	28	TL	203	A2	22.00/3.0	22.00/3.0 IF (2)	673	1750	5075	775	39	69	24800	15500	13175	27900	22475	20925
26.5-25	32	TL	206	A2	22.00/3.0	22.00/3.0 IF (2)	673	1750	5075	775	39	80	27200	17000	14450	30600	24650	22950
29.5-25	28	TL	207	A2	25.00/3.5	25.00/3.5 IF (2)	750	1873	5432	825	44	62	28000	17500	14875	31500	25375	23625
29.5-25	32	TL	207	A2	25.00/3.5	25.00/3.5 IF (2)	750	1873	5432	825	44	62	28000	17500	14875	31500	25375	23625



SM 70 (L4)

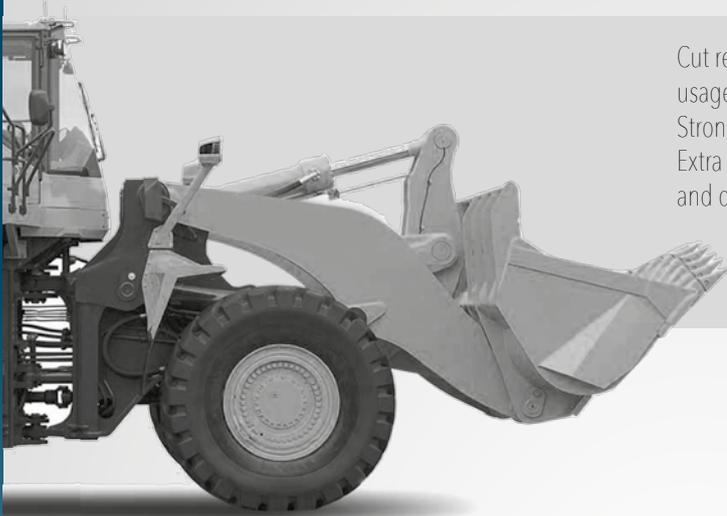

Cut resistant special tread compound reduces damages and cuts in case of over usage.

Strong loader-dozer design provides safe drive and easy rotation ability.

Extra deep tread pattern provides high traction and grip performance on muddy and dynamic surfaces.



TIRE SIZE	PR	TT/TL	LOAD INDEX	SPEED SYMBOL	RIM		INFLATED DIMENSIONS (NO LOAD)		INFLATED DIMENSIONS (W/ LOAD)		TREAD DEPTH (MM)	INFLATING PRESSURE (psi/bar)	LOAD CAPACITY PER TIRE (KG)			LOAD CAPACITY PER TIRE (KG)		
					RECOM. (INCHES)	PERMITTED (INCHES)	SECTION WIDTH MIN-MAX	OUTER DIAMETER (MM)	DYNAMIC RADIUS CIRCLE (MM)	STATIC LOADED RADIUS (MM)			OFF ROAD PURPOSES			HARD IMPROVED SURFACE		
													STATIC	10 KM/H **	25 KM/H	STATIC	5 KM/H	10 KM/H **
26.5-25	28	TL	203	A2	22.00/3.0	22.00/3.0 IF (2)	673	1798	5214	794	64	69	24800	15500	13175	27900	22475	20925
26.5-25	32	TL	206	A2	22.00/3.0	22.00/3.0 IF (2)	673	1798	5214	794	64	80	27200	17000	14450	30600	24650	22950
29.5-25	28	TL	209	A2	25.00/3.5	25.00/3.5 IF (2)	750	1921	5432	825	69	62	28000	17500	14875	31500	25375	23625
29.5-25	32	TL	209	A2	25.00/3.5	25.00/3.5 IF (2)	750	1921	5432	825	69	62	28000	17500	14875	31500	25375	23625



C+ STACKER

Maximum resistance with minimum elasticity under heavy loads.
 Long life and low wear with special tread and mixture.
 High resistance against cuts / drills and irregular wear



TIRE SIZE	PR	TT/ TL	LOAD INDEX	SPEED SYMBOL	RIM		INFLATED DIMENSIONS (NO LOAD)		INFLATED DIMENSIONS (W/ LOAD)		TREAD DEPTH (MM)	INFLATING PRESSURE (psi/bar)	LOAD CAPACITY PER TIRE (KG)			LOAD CAPACITY PER TIRE (KG)		
					RECOM. (INCHES)	PERMITTED (INCHES)	SECTION WIDTH MIN-MAX	OUTER DIAMETER (MM)	DYNAMIC RADIUS CIRCLE (MM)	STATIC LOADED RADIUS (MM)			OFF ROAD PURPOSES			HARD IMPROVED SURFACE		
													STATIC	10 KM/H **	25 KM/H	STATIC	5 KM/H	10 KM/H **
18.00-25	40	TL	206	A2	13.00/2.5	13.00(2.5 IF (2); 15.00/2.5	498	1673	4852	743	68	137	27200	17000	14450	30600	24650	22950



C+STACKER SMOOTH



Maximum resistance with minimum elasticity under heavy loads.
 Long life and low wear with special tread and mixture.
 High resistance against cuts / drills and irregular wear.



TIRE SIZE	PR	TT/ TL	LOAD INDEX	SPEED SYMBOL	RIM		INFLATED DIMENSIONS (NO LOAD)		INFLATED DIMENSIONS (W/ LOAD)		TREAD DEPTH (MM)	INFLATING PRESSURE (psi/bar)	LOAD CAPACITY PER TIRE (KG)			LOAD CAPACITY PER TIRE (KG)		
					RECOM. (INCHES)	PERMITTED (INCHES)	SECTION WIDTH MIN-MAX	OUTER DIAMETER (MM)	DYNAMIC RADIUS CIRCLE (MM)	STATIC LOADED RADIUS (MM)			OFF ROAD PURPOSES			HARD IMPROVED SURFACE		
													STATIC	10 KM/H **	25 KM/H	STATIC	5 KM/H	10 KM/H **
18.00-25	40	TL	206	A2	13.00/2.5	13.00(2.5 IF (2)); 15.00/2.5	498	1673	4852	743	62	137	27200	17000	14450	30600	24650	22950

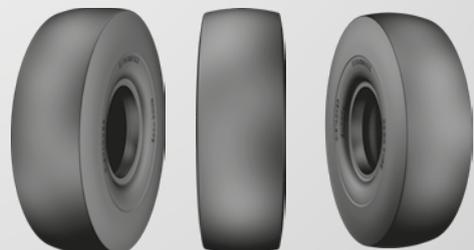

Starmaxx Industrial OTR - Tires are characterized by quality workmanship, leading edge technology, unique tread designs and excellent performance offering perfect mix of quality and value.

Our success depends on exceeding the expectations of our customers and standing behind everything we do.

Our aim is to build long term relationships with our customers by providing excellent service, quality and delivering our promises.

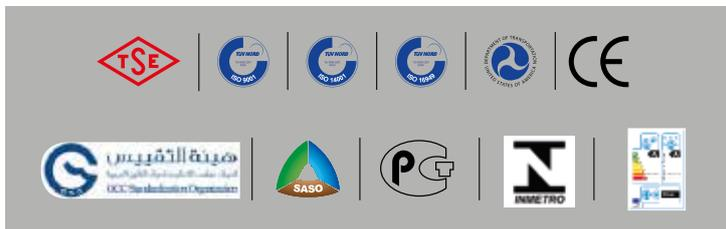

Starmaxx Industrial-OTR Tires are characterized by quality workmanship, leading edge technology, unique tread designs and excellent performance offering perfect mix of quality and value.

Our success depends on exceeding the expectations of our customers and standing behind everything we do.

Our aim is to build long term relationships with our customers by providing excellent service, quality and delivering our promises.

DISTRIBUTED BY

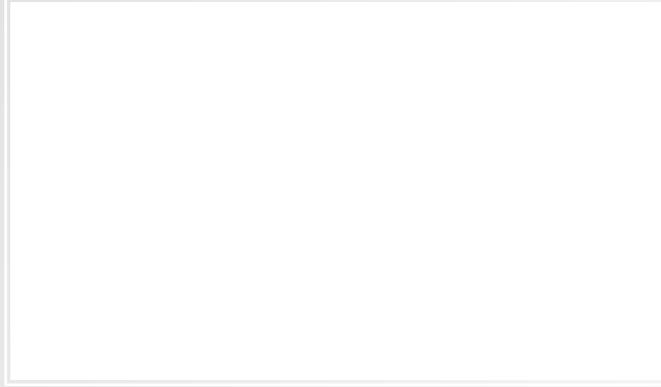

Headquarters - Factory

Petlas Tire Industry and Trade Kırşehir - Kayseri Devlet Yolu Üzeri Gölhisar Mevkii 7. km Kırşehir / TURKEY T. +90 386 252 65 50 F.+90 386 252 65 70

Int. Sales & Marketing

Petlas Tire Industry and Trade Kazım Karabekir Cd. Özcan Plaza No.124 06060 Ankara / TURKEY T. +90 312 309 30 30 F.+90 312 310 95 09

USA Sales Office

11111 E.Lincolnway STE 205 Cheyenne, WY 82001 USA

www.starmaxx.com **MADE IN TURKEY**

